

VARILLA ROSCADA

Stud - Rolled thread

Tige fileté

DIN 975

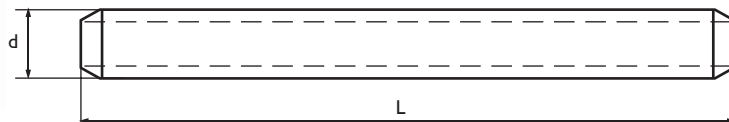

Calidad	d	L (mm)
8.8	M-8	1.000
	M-10	
	M-12	
	M-14	
	M-16	
	M-18	
	M-20	
	M-22	
	M-24	
	M-27	
	M-30	
	M-33	
	M-36	
M-39		
M-42		
M-45		

Calidad	d	L (mm)
12.9	M-10	1.000
	M-12	
	M-14	
	M-16	
	M-18	
	M-20	
	M-22	
	M-24	
	M-27	
	M-30	
	M-33	
	M-36	
	M-39	
M-42		
M-45		

Solicite precio para DIN 913 - 914 - 915 ...

TUERCAS EN T

T slot nuts

Tasseaux en "T"

DIN 508

Material: Tratado / Heat treated steel

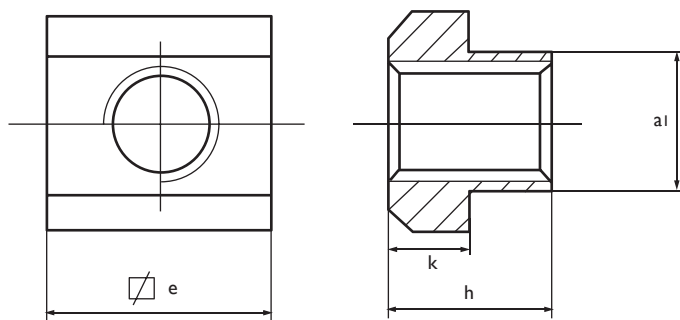

Ref.	□ a	e (mm)	h (mm)	al (mm)	k
1999	M-4 x 5	9	6,5	4,8	3,5
2000	M-5 x 6	10	8	5,7	4
2001	M-6 x 8	13	10	7,7	6
2002	M-8 x 10	15	12	9,7	6
2003	M-10 x 12	18	14	11,7	7
2004	M-12 x 14	22	16	13,7	8
2005	M-14 x 16	25	18	15,7	9
2006	M-16 x 18	28	20	17,7	10
2007	M-18 x 20	32	24	19,7	12
2008	M-20 x 22	35	28	21,7	14
2009	M-22 x 24	40	32	23,7	16
2010	M-24 x 28	44	36	27,7	18
2011	M-27 x 32	50	40	31,5	20
2012	M-30 x 36	54	44	35,5	22
20125	M-36 x 42	65	52	41,6	26
201251	M-42 x 48	75	60	47,5	30
201252	M-48 x 54	85	70	53,6	34

NORMA ANTÍGUA

Ref.	□ a	e (mm)	h (mm)	al (mm)
2013	M-8 x 12	18	14	11,7
2014	M-10 x 14	22	16	13,7
2015	M-12 x 16	25	18	15,7
2016	M-12 x 18	28	20	17,7
2017	M-14 x 18	28	20	17,7
2018	M-16 x 20	32	24	19,7
2019	M-16 x 22	35	28	21,7
2020	M-20 x 24	40	32	23,7
2021	M-20 x 28	44	36	27,7
2022	M-24 x 32	50	40	31,5
2023	M-24 x 36	54	44	35,5
20235	M-30 x 42	65	52	41,6